

BlmSchV
Regensburger BStV / Aachener BStV / Munchener BStV

4 stelle DM.186



(Max) nominal heat output	23.6 kW
Minimum heat output	4.2 kW
Efficiency at Max	91.7 %
Efficiency at Min	90.3 %
Energy Efficiency Class (A++ / G scale)	A+
Energy Efficiency Index (EEI)	115 %
Seasonal space heating energy efficiency (ηs)	78 %
Temperature of exhaust smoke at Max	155 °C ***
Temperature of exhaust smoke at Min	65 °C ***
PM / OGC / NOx at Max (13% O2)	6.4 / 0.9 / 115 mg/Nm3
PM / OGC / NOx at Min (13% O2)	5.6 / 4 / 90 mg/Nm3
CO at 13% O₂ at Min and at Max	0.011 / 0.004 %
CO₂ at Min and at Max	9.4 / 12.8 %
Boiler liters content	19 l
Maximum operating pressure	3 bar
Recommended draught at Max power	10 Pa ****
Minimum draught allowed for minimum power	6 Pa ****
Mass of smoke at Min and at Max	3.5 / 13.7 g/sec
Hopper capacity	72 l / 46 kg *
Fuel dimensions	Ø 6mm L 3÷40mm
Hourly consumption at Min and at Max	1 / 5.4 kg/h *
Autonomy at Min and at Max	47 / 9 h *
Heatable volume m3	429 / 674 / 1180 **
Combustion air inlet	Ø 50 mm
Air inlet	100 cm2
Smoke outlet	Ø 100 mm
Nominal electrical power (EN 60335-1).	107 W (max 480 W)
Supply voltage and frequency	230 Volt / 50 Hz
Net weight	256 kg

* Data that may vary depending on the type of pellets used.

**Heatable volume based on the requested power per m3 (respectively 55-35-20W/m3)

*** Flue gas temperature at the appliance outlet, to be used in the chimney sizing calculation (according to EN 13384-1)

**** Consider a minimum draught of 2 Pa in the EN 13384-1 chimney dimensioning calculations

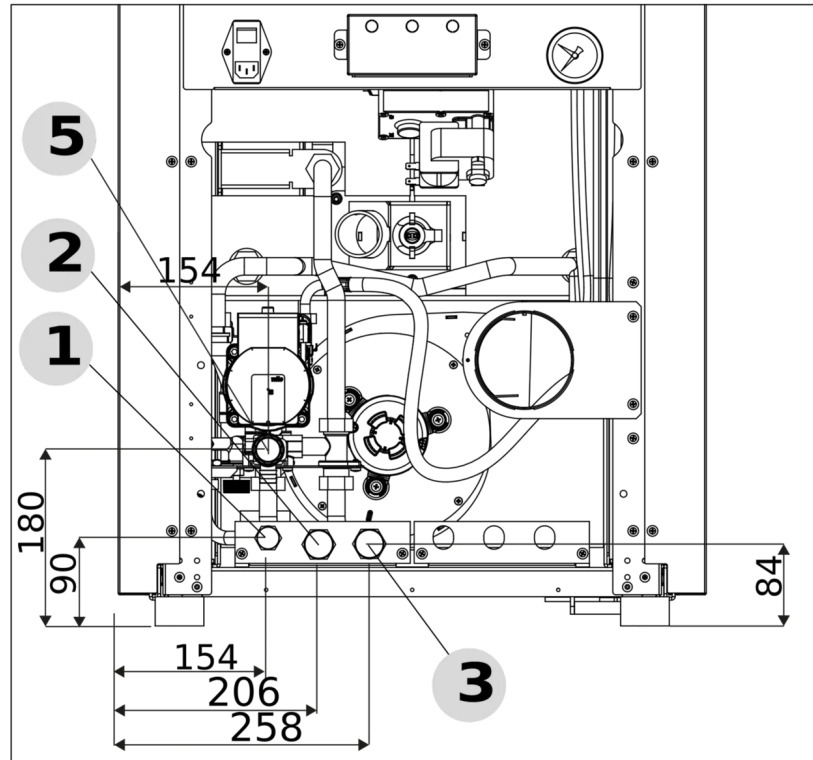

A1 = Heating water delivery
 A2 = Heating water return
 A3 = System filling / Domestic cold water inlet
 A4 = System outlet
 A5 = Domestic hot water outlet



It is strongly recommended to wash the entire system before connecting it in order to get rid of residues and deposits. Always install shutters in the system leading to the stove so as to disconnect it from the hydraulic system should it be necessary to move it, or when it requires routine and/or special maintenance. Connect the stove using flexible pipes so that the stove is not excessively constrained to the system, and to allow slight movements.